

PMDSAS Design Guidelines

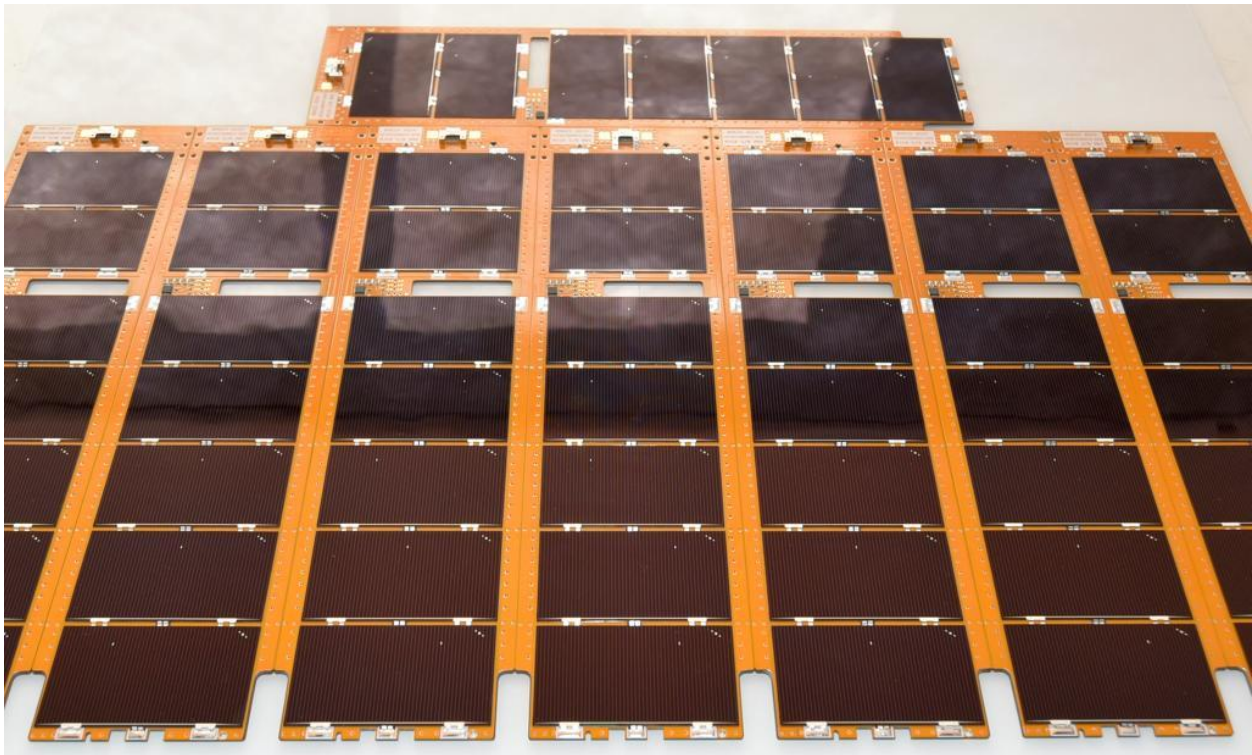

CHANGELOG

Rev.	Date	Author	Comments
A	20151027	JMM	Initial revision.
B	20170928	JMM	Corrected Table 9 voltages
C	20180619	JMM	Added fixed panel pinouts
D	20190529	JMM	Added spring torques
E	20191112	JMM	Updated cell type. Added mass numbers
E1	20200226	JMM	Added additional images to gallery, updated part numbers, pinouts

Contents

PMDSAS Design Guidelines 1

List of Figures 3

List of Tables 3

1 Overview 4

2 Panel Construction 4

3 Fixed Panels 5

4 Deployable Panels 6

 4.1 End Hinged Arrays 6

 4.2 Wrap-Around Arrays (Turkey Tail) 9

 4.3 Side Hinged Arrays 13

 4.4 SUPERNOVA™ End Hinge Array 15

5 Panel Assembly 15

6 Panel Sensors and Components 16

7 Redundancy 16

8 Electrical Connection 16

9 Solar Cell Strings 17

10 Marking & Serializing 17

11 Additional Features & Custom Panels 18

 11.1 Alternate Cells 18

 11.2 Alternate Laminates 18

 11.3 Alternate/Additional Functions 18

12 Design Considerations 18

 12.1 Proximity to Solar Cells 19

Frequently Asked Questions 20

 1) What type of solar cells do you use? 20

 2) What is your lead time on solar panels? 20

 3) Can we purchase blank, unpopulated solar panels? 20

 4) Do you provide CAD models of your hinges? 20

 5) Can you do double sided panels? 20

 6) Do you use thermal paints on your panels? 20

 7) Does it matter which type of fixed panel I use with the Pumpkin PRM (Panel Release Mechanism) 20

Gallery 21

List of Figures

Figure 1: Stowed panel supports example	6
Figure 2: End hinge configuration A (left); configuration B (right).....	7
Figure 3: End hinge configuration C (left); configuration D (right)	8
Figure 4: End hinge configuration E (left); configuration F (right).....	8
Figure 5: End hinge configuration G	8
Figure 6: End hinge configuration H	8
Figure 7: End hinge configuration I.....	8
Figure 8: End hinge configuration J.....	9
Figure 9: End hinge configuration K	9
Figure 10: End hinge configuration L.....	9
Figure 11: Wrap-Around array features deployed (left) and stowed (right)	10
Figure 12: Wrap-around hinge configuration A. End hinge top view	11
Figure 13: Wrap-around hinge configuration B. End hinge top view	11
Figure 14: Wrap-around hinge configuration C. End hinge top view	12
Figure 15: Wrap-around hinge configuration D. End hinge top view	12
Figure 16: Side hinge configuration A.....	14
Figure 17: Side hinge configuration B.....	14
Figure 18: Side hinge configuration C	14
Figure 19: Side hinge configuration D	14
Figure 20: Side hinge configuration E.....	14
Figure 21: SUPERNOVA™ with deployed end hinge array	15
Figure 22: Keep-out zones around solar cell. Stay out of hashed zone and string terminating pads. Dimensions in inches [millimeters in brackets].....	19

List of Tables

Table 1: Example layer stack up of single-sided multi-layer PMDSAS panel	5
Table 2: Standard fixed solar panels	5
Table 3: Standard fixed panel 6-pin Hirose pinouts	6
Table 4: Standard end hinged deployable panel spacing by configuration in inches [millimeters in brackets].....	7
Table 5: Standard end hinged deployable panel stowed spring torque.....	7
Table 6: Standard wrap-around deployable panel spacing by configuration in inches [millimeters in brackets]. Assuming symmetric arrays	10
Table 7: Standard wrap-around deployable panel stowed spring torque	10
Table 8: Types of 90° side hinges [millimeters in brackets].....	13
Table 9: Side hinged deployable panel spacing by configuration in inches [millimeters in brackets]	13
Table 10: Standard side hinged deployable panel stowed spring torque	13
Table 11: SUPERNOVA™ deployable panel spacing by configuration in inches [millimeters in brackets]	15
Table 12: SUPERNOVA™ deployable panel stowed spring torque	15
Table 13: Typical additional panel components and their heights. Dimensions in inches [millimeters in brackets].....	16
Table 14: Approximate V_{oc} and BOL power for different PMDSAS solar cell string configurations.....	17

1 Overview

Pumpkin's Modular Deployable Solar Array System (PMDSAS) technology combines materials, processes, design innovations and technologies to manufacture both fixed and deployable solar panels for nanosatellites. Pumpkin offers a wide variety of CubeSat-compatible solar panels depending on your requirements. Standard, commercial off-the-shelf (COTS) panels are available, as well as custom designs. Pumpkin designs both fixed and deployable panels along with associated mechanical hardware (hinges, release mechanisms, etc.); nearly all of this hardware is custom designed and manufactured by Pumpkin.

Standard panels use Spectrolab CIC¹ 30.7% NeXt Triple Junction (XTJ) Prime Solar Cells and are made using an FR4-based substrate that come in .031in [0.79mm] to .062in [1.57mm] thicknesses. Panels are typically 3.25in [82.55mm] wide.

In the event that our standard panels don't meet the requirements of your mission, Pumpkin can work with you to create a custom solution. This document covers many of the details associated with PMDSAS panels. Please refer to Section 11 Additional Features & Custom Panels for guidelines on incorporating custom features.

2 Panel Construction

PMDSAS panels are manufactured via printed circuit board (PCB) processes. Any number of nonconductive substrate layers (usually FR4, FR406 or similar/compatible materials) are sandwiched / laminated between inner layers of copper sheet. The outer copper layers – the top and the bottom of each panel – aid in locating all of the surface components, and provide for the necessary electrical interconnects. The inner copper layers are normally associated with signal routing and may be optimized for certain requirements (e.g., signals with controlled impedances). While PMDSAS is compatible with any panel thickness, Pumpkin's COTS panels utilize standard a PCB thickness of .031in [0.79mm] (except for the ISIS ANTS Solar Panel). Consult Pumpkin regarding other panel thicknesses.

Plated-through holes ("vias") conduct electrical signals through each panel, and also serve as a thermal conduit from the top/hot/solar cell side to the bottom/cold/radiator side of each panel. A "sea of vias" in each panel maximizes the thermal transfer through each panel, without compromising the panel's mechanical properties.

Electroless Nickel Immersion Gold (ENIG) plating is used on all exposed copper surfaces. The ENIG thickness is controlled to avoid embrittlement of soldered joints.

The outermost surfaces of each PMDSAS panel – i.e., the substrate and gold-plated copper of the top and bottom layers – can be covered in a variety of ways, or left exposed. Typically, a soldermask (white on top and black on bottom) is applied to the non-solar-cell areas, and then the soldermask is covered by a Kapton™ coverlay. This protects the panel and improves its emissivity.

An example layer stack up of a single-sided² multi-layer PMDSAS panel is shown below.

¹ Cell, Interconnects and Coverglass.

² I.e., solar cells only on the top.

Layer(s)	Material	Color / Finish	Purpose	Notes
Top	Kapton™ coverlay	Natural	Protection, emissivity	Solar cells cover the majority (>80%) of this surface. All copper floods (visible and under cells) are typically at chassis potential.
	soldermask	White	Reflectivity, marking	
	Copper sheet	ENIG	Interconnects, thermal, grounding	
Inner	FR4 or other laminate	Natural	Structural, isolates adjacent copper layers	Inner copper and substrate layers are repeated as required; heat flows through these layers, top-to-bottom.
	Copper sheet		Interconnects, thermal, grounding	
	FR4 or other laminate		Structural, isolates adjacent copper layers	
Bottom	Copper sheet	ENIG	Interconnects, thermal, grounding	This surface is typically devoid of any large components; it functions primarily as a conductive or emissive radiator. All copper floods are typically at chassis potential.
	Soldermask	Black	Reflectivity, marking	
	Kapton™ coverlay	Natural	Protection, emissivity	

Table 1: Example layer stack up of single-sided multi-layer PMDSAS panel

3 Fixed Panels

Panel description	P/N	PCB thickness	Max no. of cells	Mass estimate ³ [g]	Electrical connection	Required hardware
CSK fixed end solar panel	710-00764	.031 [.79]	2	34	6-pin Hirose harness	Cover or base plate with solar clips
ISIS ANTS solar panel	710-00837	.022 [.56]	2	32	6-pin Hirose harness	ISIS ANTS, ANTS cover or base plate with ANTS solar clips
1U side solar panel	710-00766	.031 [.79]	2	35	6-pin Hirose harness	Cover and base plate with solar clips
1.5U side solar panel	710-00768	.031 [.79]	3	46	6-pin Hirose harness	Cover and base plate with solar clips
2U front solar panel	710-02124	.031 [.79]	4	52	8-pin Hirose harness	Cover and base plate with solar clips
2U side solar panel	710-00770	.031 [.79]	4	54	8-pin Hirose harness	Cover and base plate with solar clips
3U front solar panel	710-00771	.031 [.79]	7	77	6-pin Hirose harness	Cover and base plate with solar clips
3U side solar panel	710-00772	.031 [.79]	7	78	6-pin Hirose harness	Cover and base plate with solar clips

Table 2: Standard fixed solar panels

³ Mass estimates are subject to change at Pumpkin's discretion.

P/N	Pin 1	Pin 2	Pin 3	Pin 4	Pin 5	Pin 6	Pin 7	Pin 8
710-00764	POS	RTN	TLM	NC	NC	NC	x	x
710-00837	POS	RTN	TLM	CHASSIS	PD ANODE	PD CATHODE	x	x
710-00766	POS	RTN	TLM	NC	NC	NC	x	x
710-00768	POS	RTN	TLM	NC	NC	NC	x	x
710-02124	POS	RTN	TLM	CSS	POS	RTN	TLM	CSS
710-00770	POS	RTN	TLM	CSS	POS	RTN	TLM	CSS
710-00770	POS	RTN	TLM	NC	NC	NC	x	x
710-00772	POS	RTN	TLM	NC	NC	NC	x	x

Table 3: Standard fixed panel 6-pin and 8-pin Hirose pinouts

4 Deployable Panels

There are many permutations for how you can arrange deployable and fixed panels. It becomes a function of the payload envelope, panel thickness, external features, and number of panels. Release mechanisms, external components and access ports may decrease the number of the cells that can fit on a face.

Some of the images in this document will feature small supports underneath the deployable panels. We recommend some sort of support or spacer for deployable panels when they are stowed. They help support the panel when in the stowed position and keep them from hitting against the CubeSat body or fixed panel. The spacers we use are typically made of Ultem or aluminum parts designed to be both a spacer and a fastener. They mount to the .200in diameter details shown in Figure 22.

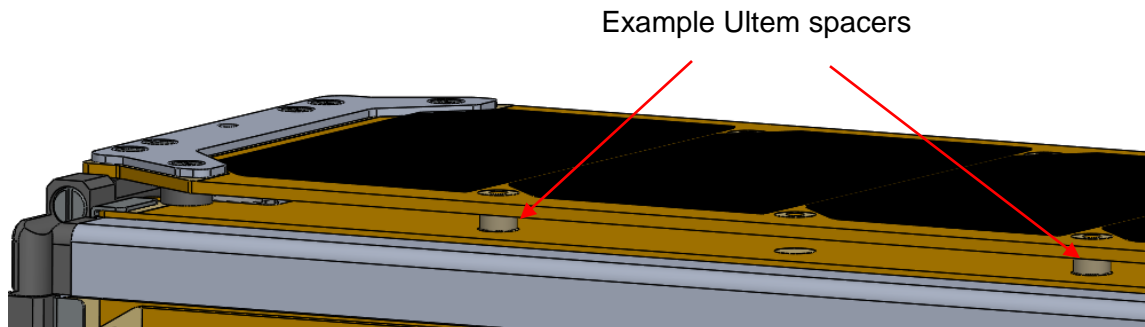

Figure 1: Stowed panel supports example

The following tables give information for the packing density of different deployed panel configurations. These do not take panel length into account and therefore do not give an expected power output.

4.1 End Hinged Arrays

End hinged deployable panels mount to either a Pumpkin base plate or cover plate using our hinge hardware. End hinges can be made with a deployment angle between 45 and 180 degrees⁴. Up to four hinged panels can fit on a base plate OR cover plate. The Table 4 covers the most common

⁴ Note: This angle cannot be changed once the order is placed.

configurations with end hinged deployable panels. Each configuration contains between 1 to 3 panels per side.

	Fixed panel	End hinge panel	Wing panel	Minimum external volume [mm]	Available height below hinged panel	Available height above top-most panel	Height between deployed Panels
A	-	.062	-	6.5	.148 [3.75]	.045 [1.15]	-
B	.031	.062	-	6.5	.117 [2.96]	.045 [1.15]	-
C	.062	.062	-	6.5	.086 [2.18]	.045 [1.15]	-
D	-	.031	-	6.5	.148 [3.75]	.076 [1.94]	-
E	.031	.031	-	6.5	.117 [2.96]	.076 [1.94]	-
F	.062	.031	-	6.5	.086 [2.18]	.076 [1.94]	-
G	-	.031	.031	6.5	.090 [2.28]	.058 [1.48]	.046 [1.17]
H	.031	.031	.031	6.5	.059 [1.49]	.058 [1.48]	.046 [1.17]
I	-	.031	.031	8.0	.148 [3.75]	.060 [1.53]	.046 [1.17]
J	.031	.031	.031	8.0	.117 [2.96]	.060 [1.53]	.046 [1.17]
K	.062	.031	.031	8.0	.086 [2.18]	.060 [1.53]	.046 [1.17]
L	-	.031	x2 .031	8.0	.090 [2.28]	.042 [1.07]	.046 [1.17]

Table 4: Standard end hinged deployable panel spacing by configuration in inches [millimeters in brackets]

	End Hinge Spring Torque [in-lbs]	1 st Wing Spring Torque [in-lb]	2 nd Wing Spring Torque [in-lb]
A	1.12	-	-
B	1.12	-	-
C	1.12	-	-
D	1.12	-	-
E	1.12	-	-
F	1.12	-	-
G	1.12	0.3	-
H	1.12	0.3	-
I	1.12	0.3	-
J	1.12	0.3	-
K	1.12	0.3	-
L	1.12	0.3	0.3

Table 5: Standard end hinged deployable panel stowed spring torque

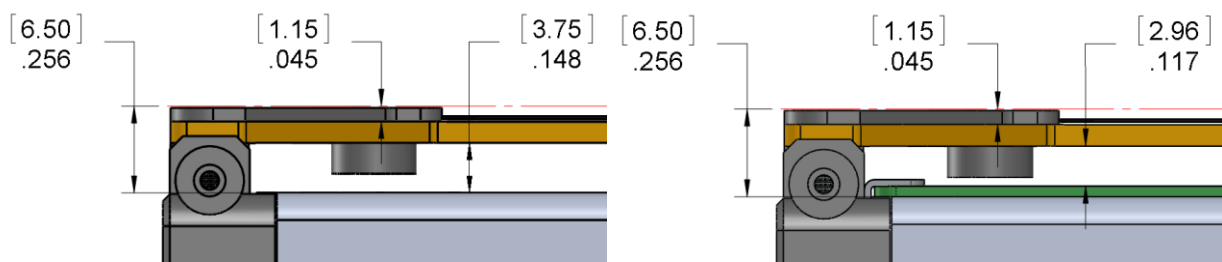

Figure 2: End hinge configuration A (left); configuration B (right)

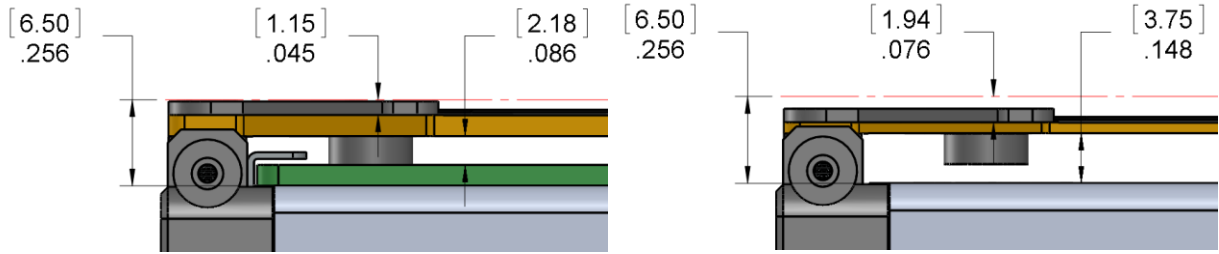

Figure 3: End hinge configuration C (left); configuration D (right)

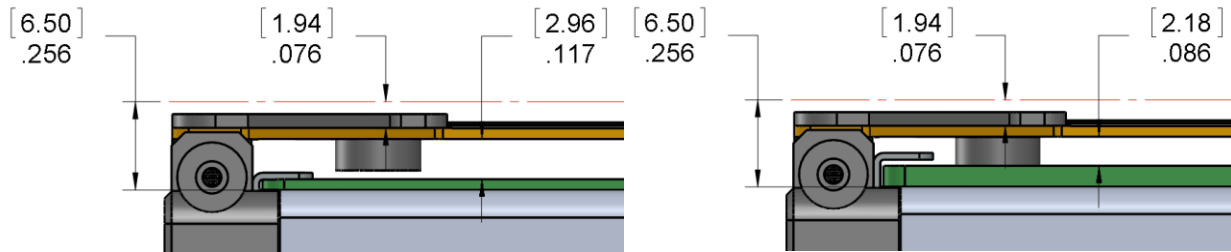

Figure 4: End hinge configuration E (left); configuration F (right)

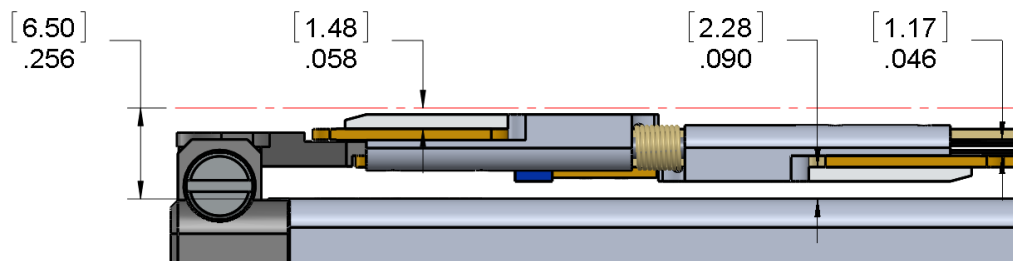

Figure 5: End hinge configuration G

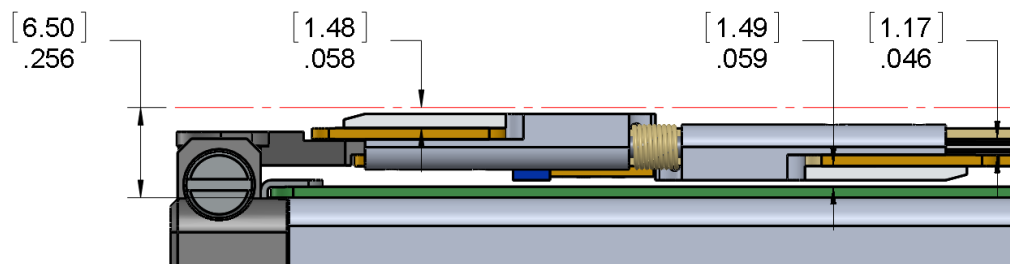

Figure 6: End hinge configuration H

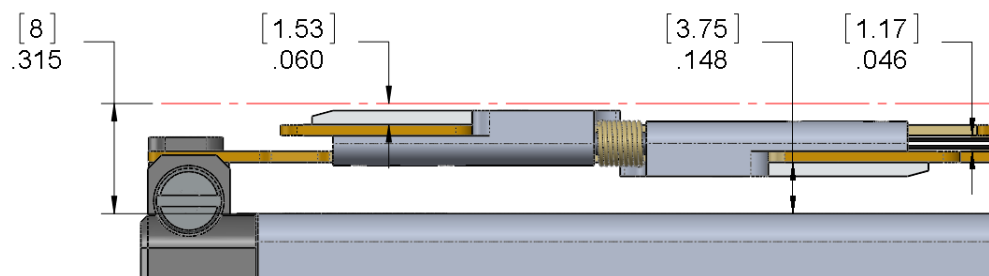

Figure 7: End hinge configuration I

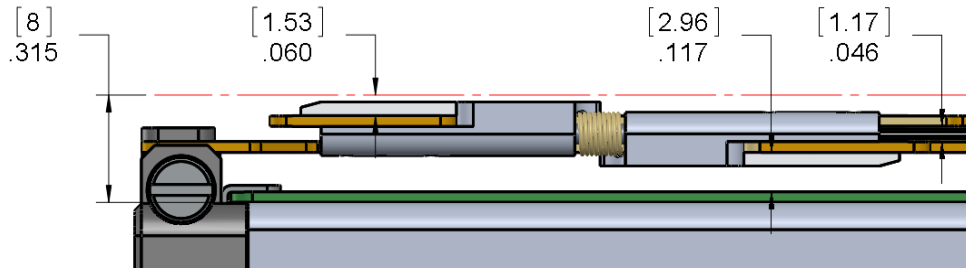

Figure 8: End hinge configuration J

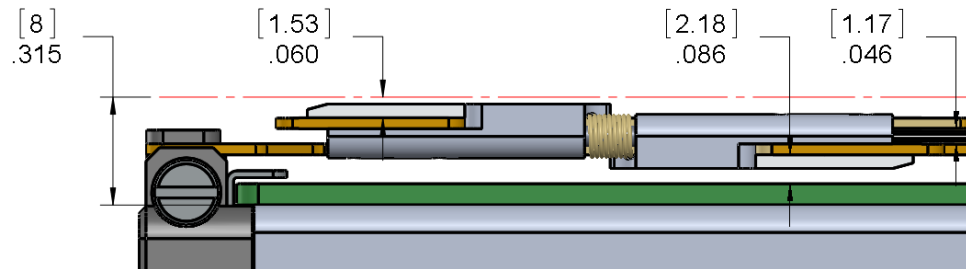

Figure 9: End hinge configuration K

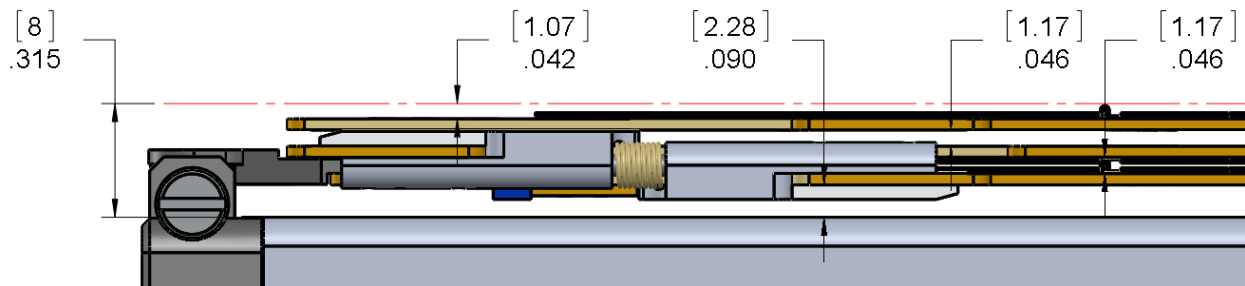

Figure 10: End hinge configuration L

4.2 Wrap-Around Arrays (Turkey Tail)

Wrap-Around arrays consist of one main spar that is end-hinged from the cover or base plate and two wing panels, one on either side of the main spar. When stowed, the main spar folds down to be parallel with the face that it is mounted on (same as end-hinge panels). The wings fold 90 degrees to the main spar and stow parallel to the adjacent faces (see images below). In order to avoid interference with the deployer rails, these 90 degree hinges must stow within the body of the CubeSat using cutouts in the chassis. There are some important design restrictions that need be followed if using a wrap-around array.

- 90 degree hinges must stow within the body of the CubeSat
- Cutouts or reliefs must exist in the chassis for the 90 degree hinges. Cutouts should give hinges a minimum .05in [1.27mm] clearance
- Bus stacks and payloads must be able to accommodate the stowed hinge intrusion
- End hinge angle can be between 45 and 180 degrees⁵

⁵ Note: This angle cannot be changed once the order is placed

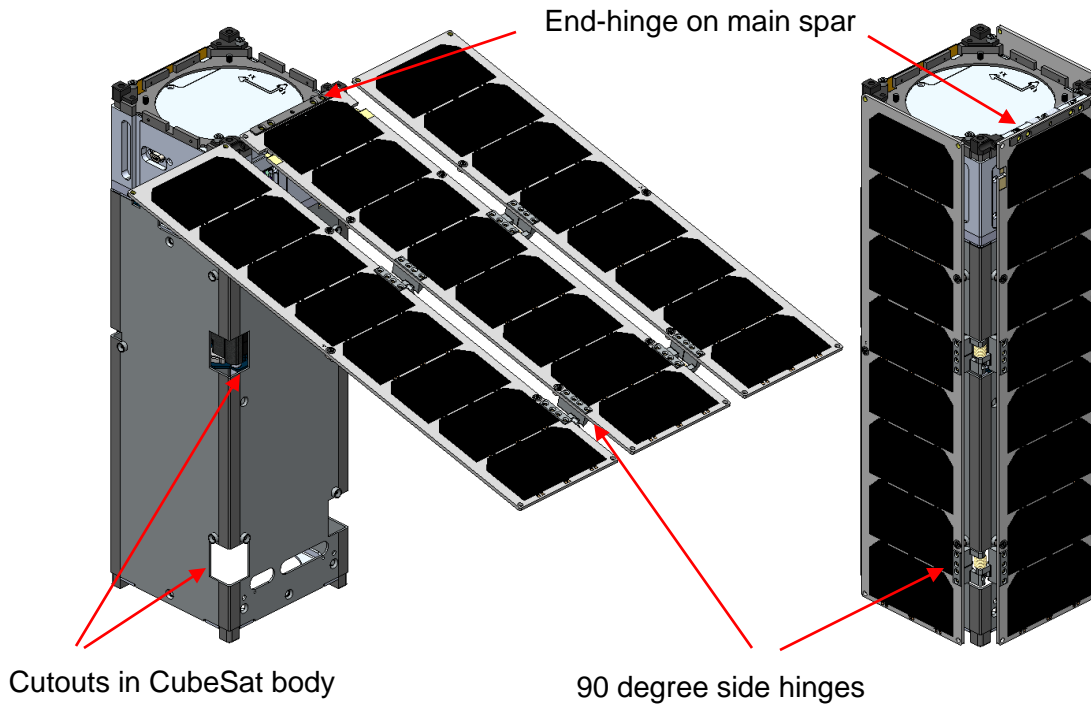

Figure 11: Wrap-around array features deployed (left) and stowed (right)

	End hinge main spar	Left side stacking	Right side stacking	Minimum external volume [mm]	Available height below main spar	Available height above main spar	Available height below side stacks	Available height above side stack	Height between panels
A	.062	.031	.031	6.5	.148 [3.75]	.045 [1.15]	.146 [3.72]	.077 [1.97]	-
B	.062	x2 .031	x2 .031	8	.148 [3.75]	.107 [2.72]	.146 [3.72]	.060 [2.54]	.046 [1.17]
C	.062	x3 .031	x3 .031	9.5	.148 [3.75]	.166 [4.22]	.146 [3.72]	.044 [1.11]	.046 [1.17]
D	.084	.084	.084	8.5	.191 [4.84]	.059 [1.50]	.191 [4.84]	.059 [1.50]	-

Table 6: Standard wrap-around deployable panel spacing by configuration in inches [millimeters in brackets]. Assuming symmetric arrays

	End Hinge Spring Torque [in-lbs]	1 st Wing Spring Torque [in-lb]	2 nd Wing Spring Torque [in-lb]	3 rd Wing Spring Torque [in-lb]
A	1.12	4.8	-	-
B	1.12	4.8	0.3	-
C	1.12	4.8	0.3	0.3
D	1.12	-	-	-

Table 7: Standard wrap-around deployable panel stowed spring torque

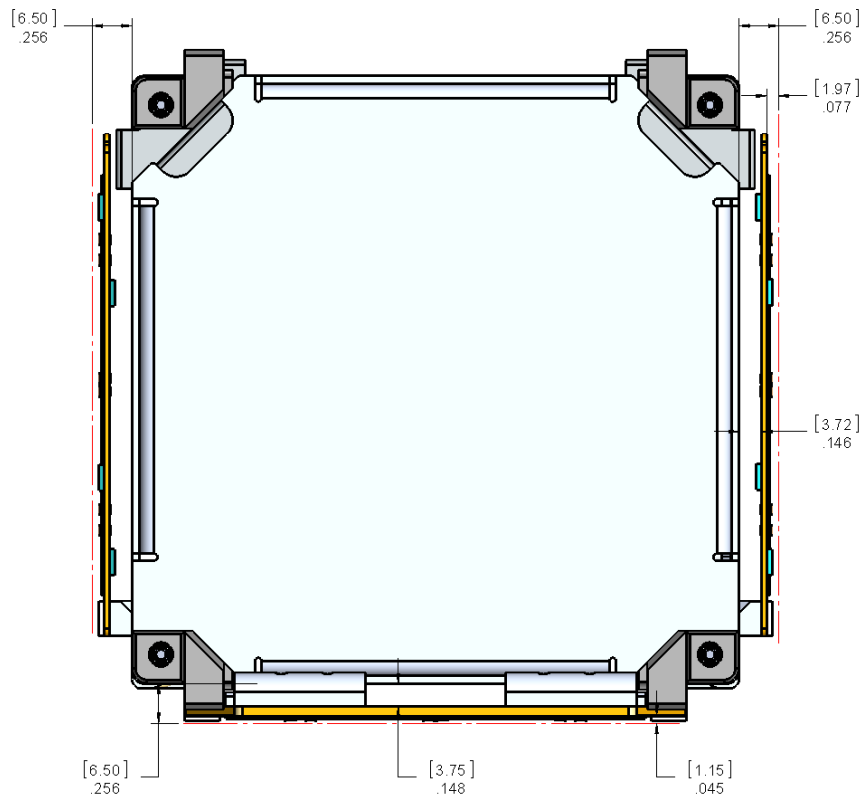

Figure 12: Wrap-around hinge configuration A. End hinge top view

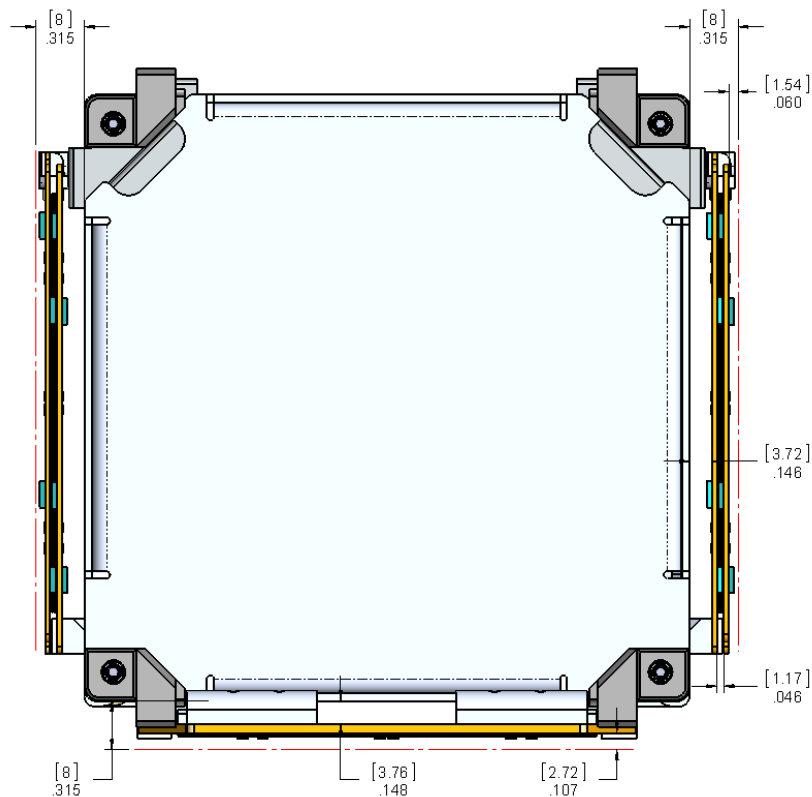

Figure 13: Wrap-around hinge configuration B. End hinge top view

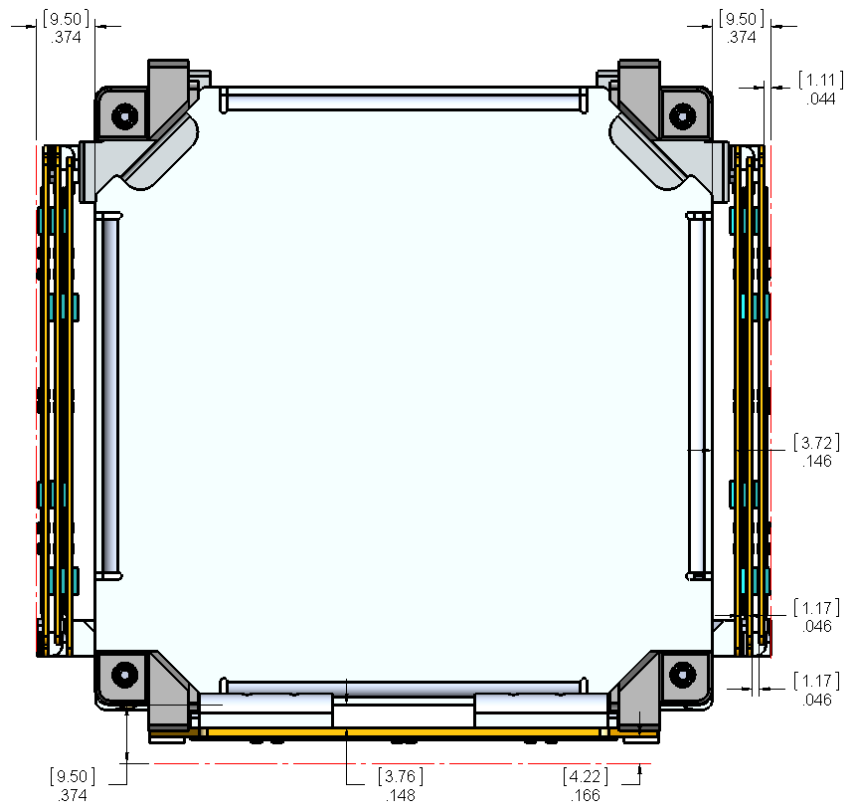

Figure 14: Wrap-around hinge configuration C. End hinge top view

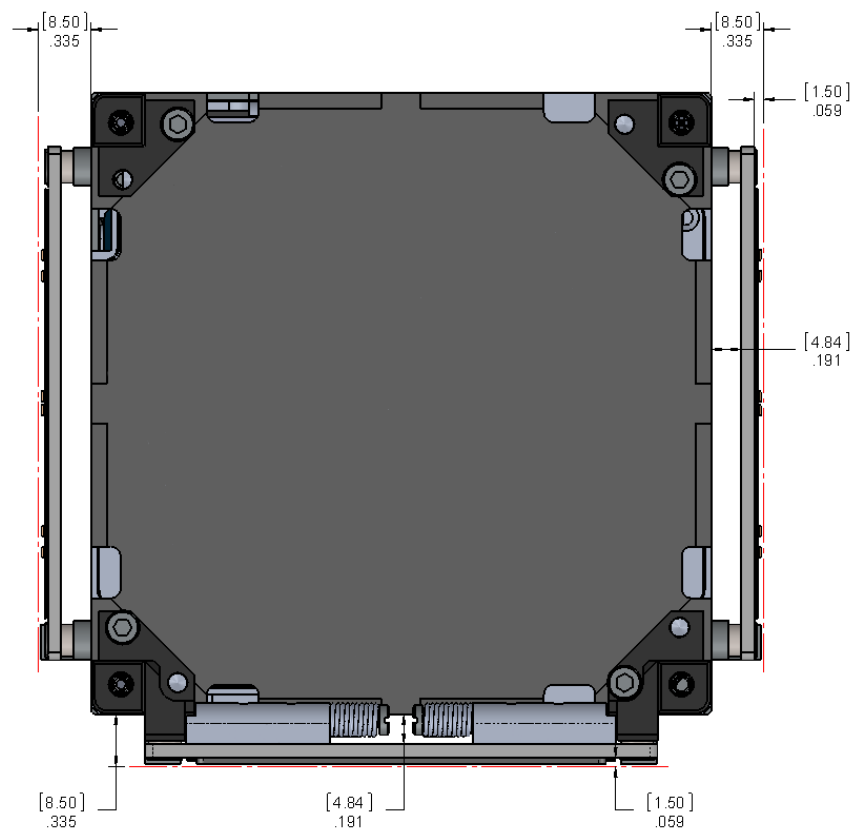

Figure 15: Wrap-around hinge configuration D. End hinge top view

Pumpkin manufactures three different 90 degree side hinges that vary in occupied volume and off-set distance. All 90 degree side hinges consist of three main hinge parts; an inner, an outer left, and an outer right. Configurations A, B, and C use the standard Side Hinge. Configuration D uses the Compact Side Hinge.

Configuration	Hinge length	Inner hinge	Outer left	Outer right	Spring
A, B, C	1.150 [29.21]	703-00633	703-00634	703-00635	703-00631
D	.866 [22.00]	703-01065	703-01066	703-01067	703-00631

Table 8: Types of 90° side hinges [millimeters in brackets]

4.3 Side Hinged Arrays

Side hinged arrays are possible with the CubeSat Kit™ Pro Chassis. The Pro Chassis enables us to mount hinges along the long axis of the CubeSat. These hinges can deploy to angles between 45 and 180 degrees. Side-hinged deployable panels can only be done with a Pro Chassis or with a customer chassis with the appropriate mating features. Should you decide to use your own chassis, our side hinges require a minimum of .100in [2.54mm] of thread engagement into the chassis.

Side hinge arrays can be hinged on the left or the right of the panel. Side hinge arrays can also be made into a wrap-around hybrid. The side hinged panel takes the place of the end hinged panel in this case.

	Fixed panel	Deployed panel 1	Deployed panel 2	Minimum external volume [mm]	Available height below hinged panel	Available height above top-most panel	Height between deployed panels
A	-	.062	-	6.5	.136 [3.45]	.058 [1.47]	-
B	.031	.062	-	6.5	.105 [2.67]	.058 [1.47]	-
C	-	.031	-	6.5	.166 [4.22]	.058 [1.47]	-
D	.031	.031	-	6.5	.135 [3.43]	.058 [1.47]	-
E	.031	.031	.031	8.0	.135 [3.43]	.044 [1.12]	.046 [1.17]

Table 9: Side hinged deployable panel spacing by configuration in inches [millimeters in brackets]

	Body Hinge Spring Torque [in-lbs]	Wing Spring Torque [in-lb]
A	0.3	-
B	0.3	-
C	0.3	-
D	0.3	-
E	0.3	0.9

Table 10: Standard side hinged deployable panel stowed spring torque

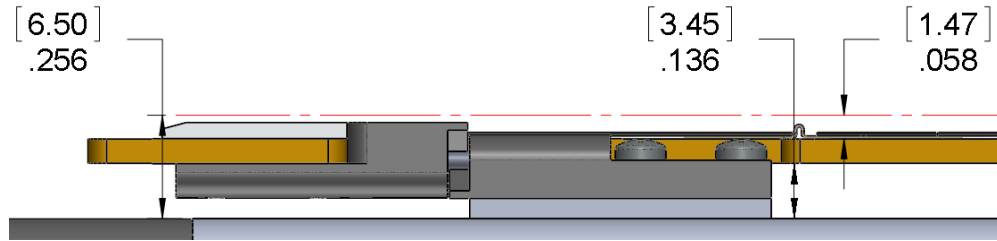

Figure 16: Side hinge configuration A

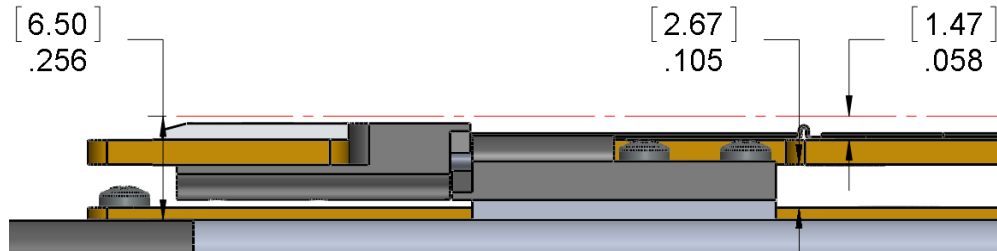

Figure 17: Side hinge configuration B

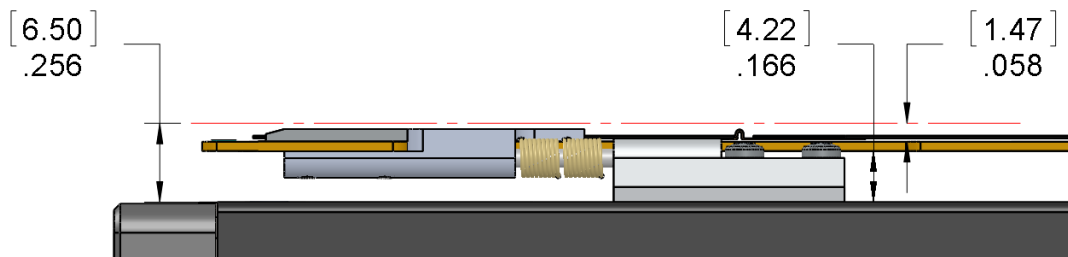

Figure 18: Side hinge configuration C

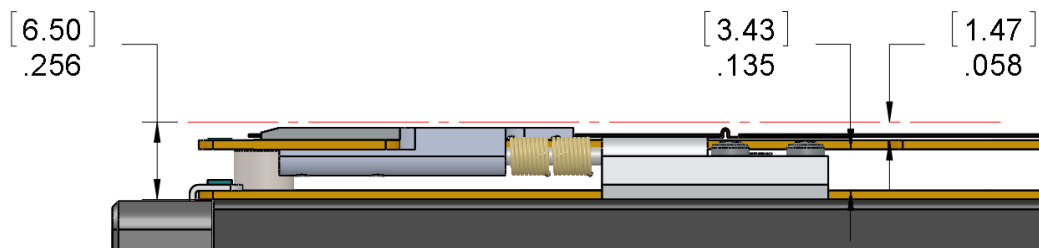

Figure 19: Side hinge configuration D

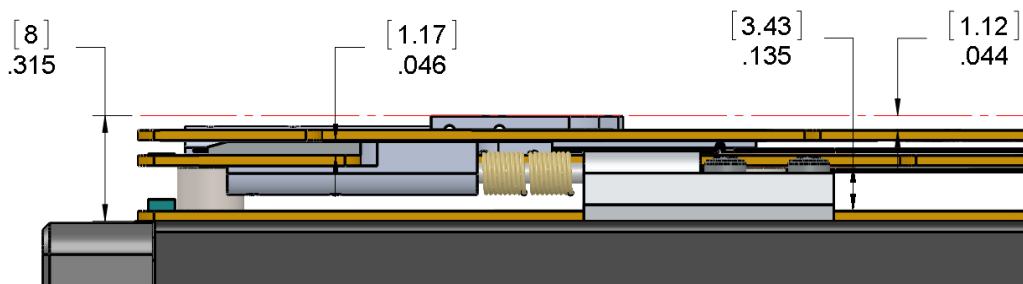

Figure 20: Side hinge configuration E

4.4 SUPERNOVA™ End Hinge Array

SUPERNOVA™ is Pumpkin’s 6U architectural system that utilizes the Planetary Science Corporation’s CSD (Canisterized Satellite Dispenser). We currently have one end hinged array configuration designed for SUPERNOVA as seen in Figure 21.

The array features four end-hinged deployable solar panels, .062in [1.6mm] thick. The two side panels (+/-X) have 8 solar cells each while the top/bottom panels (+/- Y) have 24 solar cells each. All panels deploy to 90 degrees from the stowed position.

Panel	External volume [mm]	Available height below hinged panel	Available height above top-most panel
-X side panel	8.5	.079 [2.01]	.182 [4.64]
+X side panel	8.5	.079 [2.01]	.182 [4.64]
+Y panel	5.25	.079 [2.01]	.065 [1.65]
-Y panel	5.25	.079 [2.01]	.065 [1.65]

Table 11: SUPERNOVA™ deployable panel spacing by configuration in inches [millimeters in brackets]

Panel	Spring Torque [in-lbs]
-X side panel	1.5
+X side panel	1.5
+Y panel	2.9
-Y panel	2.9

Table 12: SUPERNOVA™ deployable panel stowed spring torque

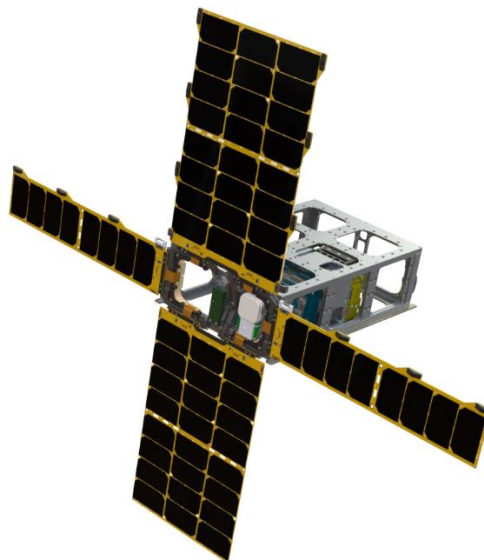

Figure 21: SUPERNOVA™ with deployed end hinge array

5 Panel Assembly

Pumpkin has developed a proprietary method for laying CICs down onto solar panel PCBs. Pumpkin utilizes pressure-sensitive polyimide film to bond each CIC to the solar panel. Special attention is paid to avoiding any trapped air bubbles between the panel, the film and the CIC.

Because no epoxies or RTVs are used in solar cell laydown, the CICs remain extremely flat and undistorted. Additionally, the thermal path from each solar cell to the heat-sinking and grounded copper layers beneath is minimized, thereby improving heat flow through the panel.

Electrical connections are made between adjacent cells and endpoints of each string of solar cells via soldering or conductive epoxies, dependent on the application. Additional components (e.g., blocking diodes) are typically soldered in place on the top or bottom of the PMDSAS panel. Thermally-sensitive components like blocking diodes and bleed resistors are covered with a thermally encapsulating epoxy.

6 Panel Sensors and Components

PMDSAS panels will have standard and optional additional components. For reference, those components are listed below along with their heights. Component heights take encapsulation (where applicable) into account.

Sensor type	Part description	Part number	Height	Notes
Temperature sensor	Analog output, absolute Kelvin, SO-8 package	LM335A	.07 [1.8]	Compatible with common nanosat EPSes
	Customer-specified	Varies	Varies	Often SOT-23 or smaller packages
Blocking diode	2A Schottky	Varies	.05 [1.2]	
Photodiode	For coarse sun sensors	Varies	.05 [1.2]	
Bleed resistor	Shunts charge to chassis	Varies	.05 [1.2]	
Harness connector	POS, RTN and telemetry (typically temperature)	Hirose DF13 series	.14 [3.5]	

Table 13: Typical additional panel components and their heights. Dimensions in inches [millimeters in brackets]

7 Redundancy

PMDSAS panels implement redundancy in several critical areas.

Every solar cell has at least two independent interconnects for its POS and RTN terminals.

Each solar cell string implements at least two blocking diodes, and preferably four (two on top and two on bottom).

All signal-carrying vias are implemented in multiple instances wherever possible.

8 Electrical Connection

There are two major types of electrical connections; panel-to-panel and panel-to-bus. Panel-to-panel connections can either be done through the hinges or by way of a flex connector. Connection through hinges can only be done if the hinge in question is not touching the CubeSat body. Panel-to-bus connection can be done using a flex connector or through a harness. Flex is not inexpensive

and is typically custom. Flex may also require relief cutouts in the chassis in order to accommodate the minimum bend radius. Alternative connections can be proposed but they must have a minimal drag force in relation to the spring force of the hinges.

9 Solar Cell Strings

The Spectrolab® XTJ Prime cells that Pumpkin uses as its standard CIC each generate a V_{OC} of approximately 2.5Vdc and an I_{SC} of ca. 400mA. Each CIC includes an integral back diode; this diode lies underneath the solar cell and is not visible in a finished PMDSAS panel.

Each individual string of solar cells is terminated by a parallel-connected pair of blocking Schottky diodes. This prevents strings connected in parallel from feeding power into unlit strings / panels.

Most nanosatellite electrical power systems (EPS) are designed for input voltages in the 2.5-20Vdc range. Therefore typical CubeSat-class solar panels simply connect all of the available solar cells on each panel together into a single string, in a so-called NS1P configuration. For example, a 7-cell PMDSAS panel for a 3U CubeSat will have a V_{OC} of approximately 17.5Vdc. Where real estate permits, PMDSAS panels with greater string voltages are available, up to a maximum of ca 48Vdc. Above 48Vdc additional, secondary concerns re arcing come into play; for strings longer than roughly 19 cells, strings should be connected in parallel.

Number of XTJ Prime-class solar cells	Configuration	String voltage (V_{oc} , V_{dc})	Nominal power (BOL, AM0)
1	1S1P	2.5	1W
2	2S1P	5.0	2W
3	3S1P	7.5	3W
4	4S1P	10.0	4W
5	5S1P	12.5	5W
6	6S1P	15.0	6W
7	7S1P	17.5	7W
8	8S1P	20.0	8W
12	12S1P	30.0	12W
24	12S2P	30.0	24W

Table 14: Approximate V_{oc} and BOL power for different PMDSAS solar cell string configurations

10 Marking & Serializing

Each PMDSAS panel includes text markings of its Pumpkin PCB part number (705-XXXXX), revision (A, B, ...) and other important information. These markings are integral to the PCB CAD design of the panel, and are often provided predominantly on the top side of the panel.

Each PMDSAS panel is serialized with a Pumpkin S/N and – optionally – customer-specified information. Pumpkin serial numbers implement a date code along with individual unit numbers and optional codes. For example, “15H0101.0” represents the first PMDSAS panel built in September of 2015 of a given type ... “15H0102.0” is the next of the same type, etc. Note that when a customer orders multiple different types of PMDSAS panels together, they may have the same serial numbers (because the part types are different).

Serial numbers are laser-inscribed onto each PMDSAS panel.

11 Additional Features & Custom Panels

Different missions may require additional sensors, connectors, etc. that are not normally included in our designs. Additional features can be added as long as they follow some general guidelines.

11.1 Alternate Cells

Pumpkin's PMDSAS process is optimized around Spectrolab's space-proven line of 40x70mm XTJ Prime CICs. On custom panels, Pumpkin may be able to utilize cells from other manufacturers (again, at additional cost). Pumpkin works only with CICs – individual cells without cover glass or interconnects will not be considered. Pumpkin may accept user-provided UTJ/XTJ/XTJ Prime CICs provided they are in as-new condition; a credit will be applied in these cases, please contact the factory.

11.2 Alternate Laminates

Because the PMDSAS process is compatible PCB production, Pumpkin can provide PMDSAS panels made from materials other than the usual FR4/FR406 substrates. For example, PMDSAS panels can be constructed with Rogers® Roxxxx laminates for applications that require dielectric constants or other material properties unavailable in FR4. Pumpkin has developed processes to support specialized laminates in PMDSAS panels.

11.3 Alternate/Additional Functions

PMDSAS panels can combine their traditional role of hosting solar cells with alternate, user-specified functionality. For example, a customer required solar cells on the top side of each panel, along with a large number of connectors and interconnects – some requiring controlled impedances – on the bottom. Pumpkin delivered a resulting ten-layer PMDSAS fixed panel that satisfied all of the customer requirements. In another example, the customer wanted a reflectarray⁶ on the bottom of the PMDSAS panel, instead of the typical copper flood. Pumpkin developed a process whereby the customer's bottom-layer copper design was merged with the rest of the PMDSAS layers, to result in a single PCB that was manufacturable via standard PCB board house techniques.

12 Design Considerations

Different missions may require additional sensors, connectors, etc. that are not normally included in our designs. Additional features can be added as long as they follow some general guidelines.

⁶ A carefully controlled pattern of copper and voids over a tightly-specified substrate that functions as a beam-shaper at very high frequencies.

12.1 Proximity to Solar Cells

Any cutout or electronic component must be a certain distance from the solar cells. The image below details the keep-out zone around the solar cell (hashed area). If necessary, a round part or cutout with a maximum diameter of .200in [5.08mm] may be located any of the four locations shown in the figure below.

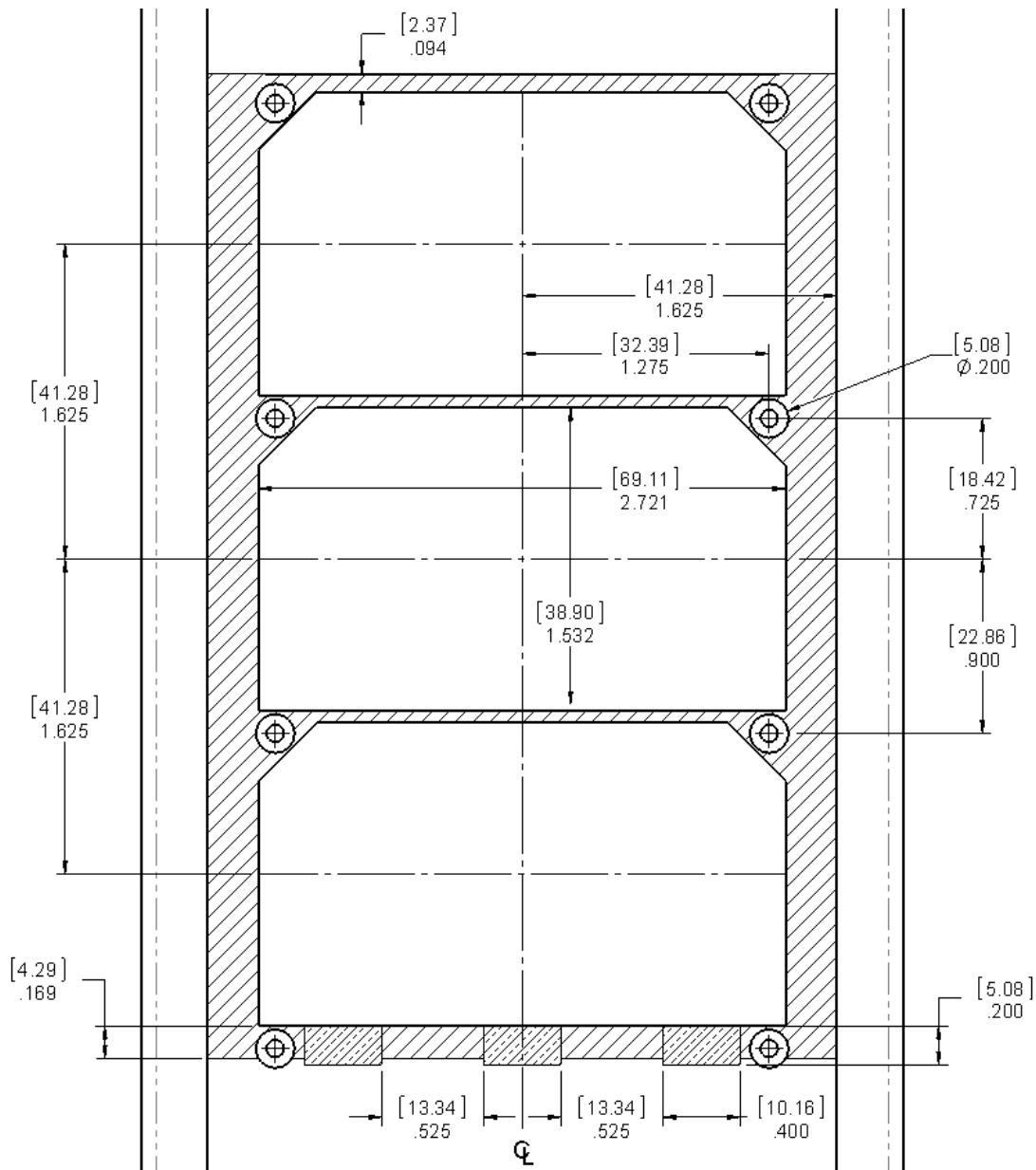

Figure 22: Keep-out zones around solar cell. Stay out of hashed zone and string terminating pads. Dimensions in inches [millimeters in brackets]

Frequently Asked Questions

1) What type of solar cells do you use?

26.62cm² Spectrolab 30.7% NeXt Triple Junction (XTJ) Prime solar cells in CIC form.

2) What is your lead time on solar panels?

Standard panels have a lead time of 30 business days. Custom panels have a lead time of 45-60 business days from sign-off by both Pumpkin and the customer on all engineering documents.

3) Can we purchase blank, unpopulated solar panels?

No, the design of the solar panel is part of our proprietary process which we don't want to leave exposed.

4) Do you provide CAD models of your hinges?

No. CAD is only supplied in an overly simplified form and only to customers who have custom panel designs. Drawings are also proprietary and will not be released.

5) Can you do double sided panels?

Yes

6) Do you use thermal paints on your panels?

No.

7) Does it matter which type of fixed panel I use with the Pumpkin PRM (Panel Release Mechanism)

Yes. The Pumpkin PRM is only compatible with .031in fixed panels.

Gallery

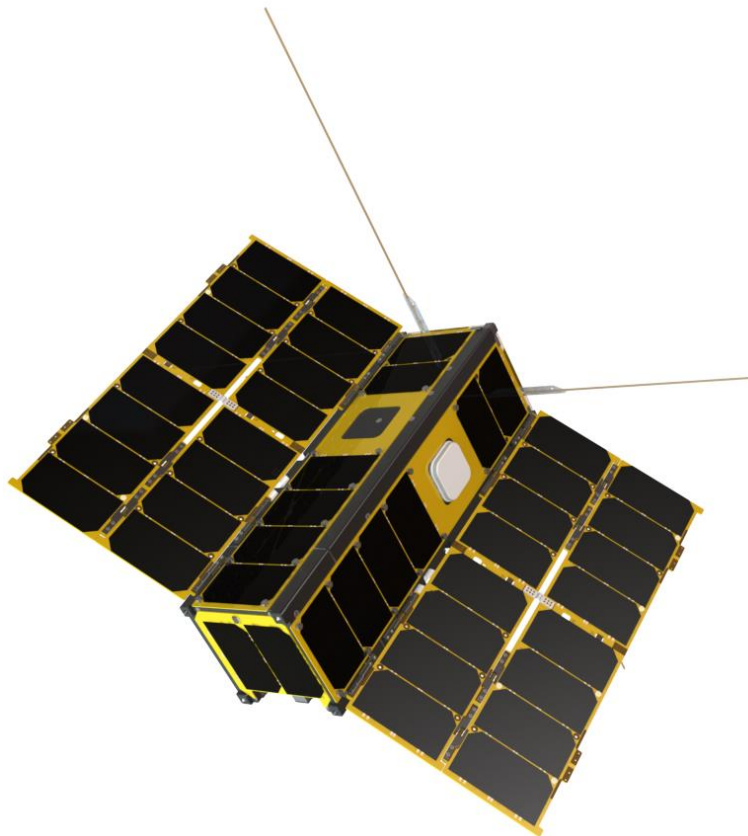

Example side hinge double deployable array using 135° hinges

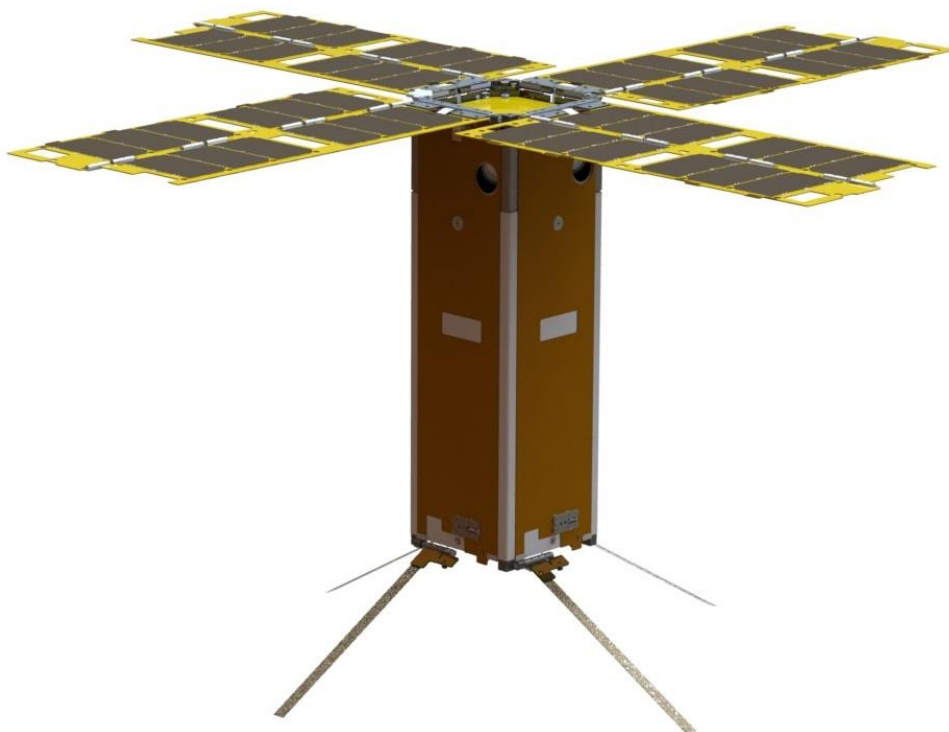

Example end hinge array using 90° hinges



SUPERNOVA™ with 64W array stowed



Deployable Articulated Solar Array (DASA)

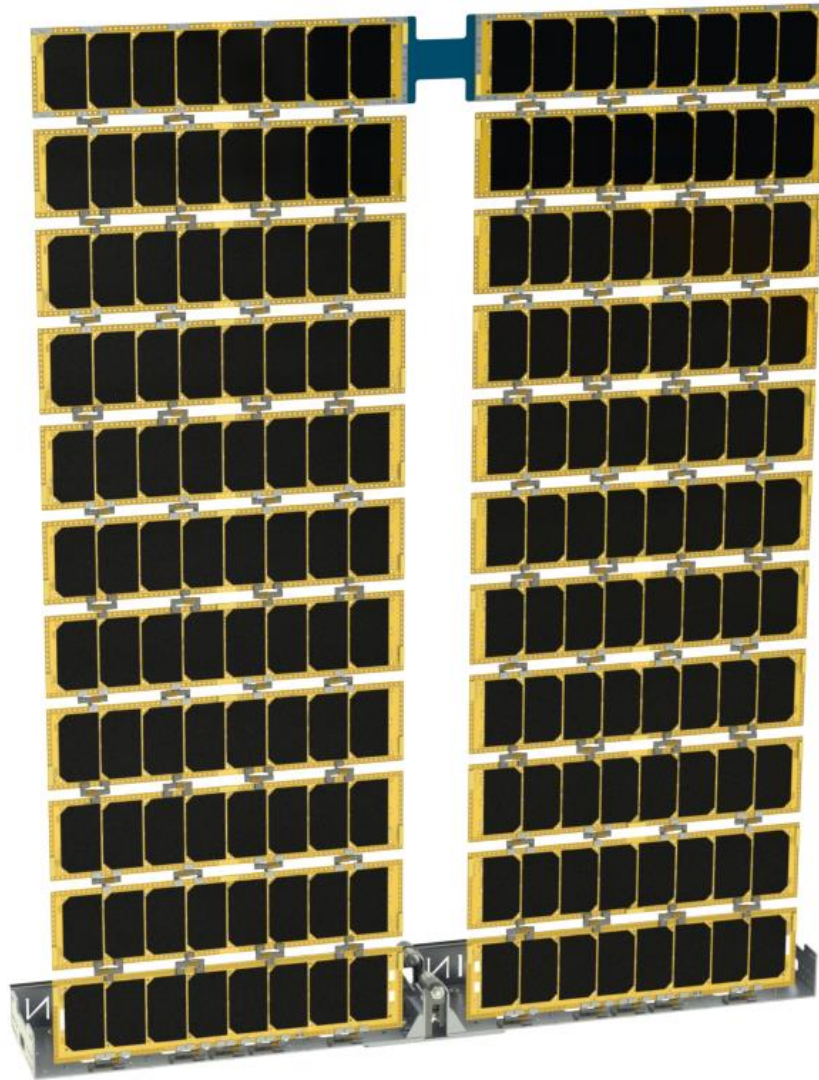

Deployable Clamshell Solar Array (DCSA) 11-Panel